

# **MCE**

Magnetic Stripe Card Reader/Writer  
(High & Low Coercivity)

# **Programmer's Manual**

**Document #: PM017-U**

**Revision G**

**Apr. 06, 2005**

# NOTICE

The issuer of this manual has made every effort to provide accurate information. The issuer will not be held liable for any technical and editorial omission or errors made herein; nor for incidental consequential damages resulting from the furnishing, performance or use of this material. This document contains proprietary information that is protected by copyright. All rights are reserved. No part of this document may be photocopied, reproduced, or translated without the prior written consent of the issuer. The information provided in this manual is subject to change without notice.

## Agency Approval

- Specification for FCC Class B
- Specification for CE Class B
- Product Certificate by Taiwan BSMI (Bureau of Standards, Metrology and Inspection)

NOTE: This equipment has been tested and found to comply with the limits for a Class B digital device, pursuant to part 15 of the FCC Rules. These limits are designed to provide reasonable protection against harmful interference in a residential installation.

This equipment generates, uses and can radiate radio frequency energy and, if not installed and used in accordance with the instructions, may cause harmful interference to radio communications. However, there is no guarantee that interference will not occur in a particular installation. If this equipment does cause harmful interference to radio or television reception, which can be determined by turning the equipment off and on, the user is encouraged to try to correct the interference by one or more of the following measures:

- Reorient or relocate the receiving antenna.
- Increase the separation between the equipment and receiver.
- Connect the equipment into an outlet on a circuit different from that to which the receiver is connected.
- Consult the dealer or an experienced radio/ TV technician for help.

You are cautioned that any change or modifications to the equipment not expressly approve by the party responsible for compliance could void your authority to operate such equipment.

□□□□ :

□□□□□□□□ , □□□□□□□□□□ , □□□□□□□□□□ , □□□□□□□□ , □□□□□□□□□□□□□□  
□□□□ .

# WARRANTY

This product is served under one-year warranty to the original purchaser. Within the warranty period, merchandise found to be defective would be repaired or replaced. This warranty applies to the products only under the normal use of the original purchaser, and in no circumstances covers incidental or consequential damages through consumers' misuse or modification of the products.

# PREFACE

This manual provides detailed information relating to the overall operational, electrical, mechanical, environmental and functional aspects of the **MCE**. This document should be read and understood prior to initial operation of the product. For ease of installation and programming use, we have addressed everything from its attractive features to its various configurations. When designing the MCE, we selected what we feel are the most useful features and functions. If in some cases you find that your specific needs differ from our existing products, we welcome your comments and suggestions. Custom-designed models are also available.

If further questions do arise, please call for technical support, our FAE will assist you in any way we can.

## Table of Contents

<b>Section 1</b>	<b>Introduction</b>	
□	Accessories of MCE.....	1-1
□	Warranty.....	1-1
<b>Section 2</b>	<b>General Description</b>	
<b>Section 3</b>	<b>Technical Specifications</b>	
<b>Section 4</b>	<b>Setup</b>	
<b>Section 5</b>	<b>Utilities Test Program</b>	
□	System Requirement.....	5-1
□	Test Program Installation.....	5-1
<b>Section 6</b>	<b>Command and Response</b>	
<b>Section 7</b>	<b>Data Format</b>	
<b>Section 8</b>	<b>Communication Sequence</b>	
□	MCE INITIALIZATION.....	8-1
□	Write Data to MCE.....	8-1
□	Read Data to MCE.....	8-2
<b>Section 9</b>	<b>Addendum</b>	
□	Write Data to Magnetic Card.....	9-1
□	Write Raw Data to Magnetic Card.....	9-2

# Section 1 Introduction

Thank you for purchasing the MCE Manual Swipe Magnetic Card Reader/Writer. It is ideal for access control, time keeping, banking, ID recognition & credit verification and related applications. In fact, wherever a magnetic stripe ID or transaction card is used, one can find a related use for the versatile, user-friendly MCE reader/writer.

The MCE is designed to offer a reading and writing solution of high and/or low coercivity cards that will attractively complement an existing system.

## Accessories of MCE

**Make sure all the following accessories are contained in your package:**

1. Switch power Supply, AC 110~240V in / DC 24V, 2.2A out.
2. Power cord.
3. Signal cable (DB9 to RJ45, 1.5m / USB attachment cable optional).
4. Utility disk (A/P S/W).
5. Blank Hi-Co test card (or and Low-Co test card).
6. Programmer's manual.

## Warranty

One year after purchase of MCE, any alteration and/or erasure or modification of the MCE will void the warranty.

## **Section 2 General Description**

The MCE series is designed to read and/or write high or low coercivity magnetic cards. It can encode and verify up to 3 tracks of data simultaneously. It communicates with a host computer or other terminal using a standard RS-232 interface.

## Section 3 Technical Specifications

ITEM SPECIFICATION	
Standard ISO7811	
<b>Electrical</b>	
Consumption	Current/operating Typical 350mA Max
	600mA plus for each writing track
Communication	Standard RS232 signal voltage levels. Default, 9600 Baud, None Parity, 8 bits
Power supply	External switching Power 24V/2.2A regulated
<b>Interconnection</b>	
Cable RJ45->DB9,	5 feet
Pin Assignment DB-9	1.shield
	2.TXD / MCE data transmit
	3.RXD / MCE data receive
	4,6,7,8,9, no connection
	5. circuit ground
<b>Mechanical</b>	
Body	ABS 94V-0 / Metal housing optional
Swipe	Manual, single direction
Outline 210Lx68Wx60H	mm
Weight 1.5Kg	approx.
<b>Environment</b>	
Operation -10°C	to 60°C
	10 to 85% humidity, non condensing
Storage -30°C	to 70°C
	10 to 90% humidity, non condensing
<b>Performance</b>	
Read Circuit	Track 1&3 210bpi
	Track 2,75 or 210 bpi
Bit per Char	5-7 bit per char.
Media Speed	Read, 5-50 ips (read speed 5-40 ips for track 2 at 210bpi)
	Write, 5-30
Media Coercivity	Read 300-4000 Oe Mag. Card
	MCE-XHC write 2750-4000 Oe Mag. Card
	MCE-XHL write 300-4000 Oe Mag. Card
Media Thickness	0.76-1.2mm
Jitter Card	Read bit to bit interval <+/-15% card
	Write bit to bit interval <+/-10%,Sub interval<+/-12% at 30ips

Low amplitude Card	Read 60% for both 75& 210bpi			
Error Rate	Read < 0.5%			
Write	< 0.8%			
Media Swipe	Head life 1,000,000 passes for both read & write head			
Configuration Available Model	Model Read/Write	Track	Hi-C	Lo-C
	MCE-3HC 1,2&3 R/W			R
	MCE-5HC 1&2 R/W			R
	MCE-1HL 2 R/W			R/W
	MCE-3HL 1,2&3 R/W			R/W
	MCE-5HL 1&2 R/W			R/W

## Section 4 Setup

1. Power off your system (PC).
2. Connect PC and MCE as below.

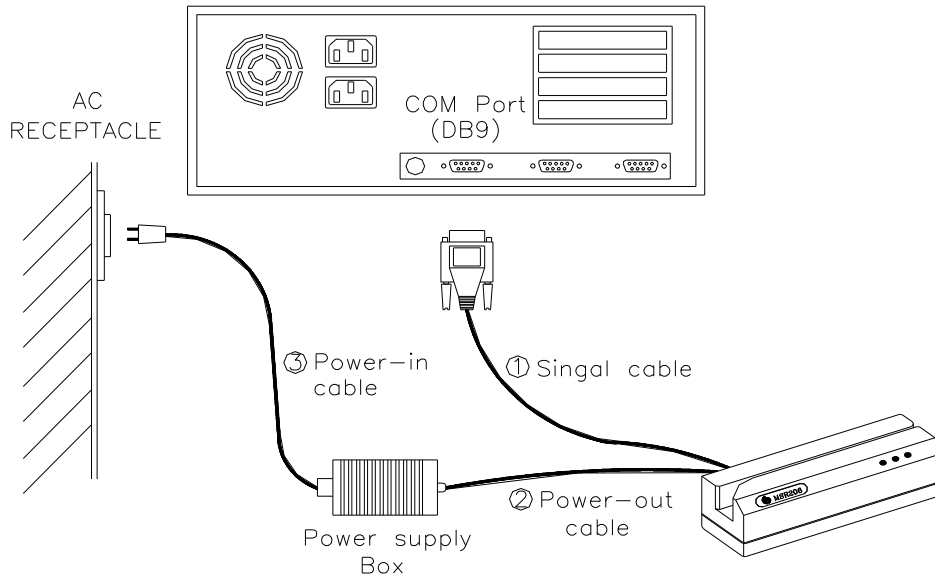

3. Connect DB9 of signal cable to a free serial port then connect RJ45 at the other end of the cable to MCE.
4. Connect outer plug of Power-out cable to the power inlet of MCE.
5. Connect Power-in cable to Power supply and AC receptacle (110V~240V).
6. Power on your system (PC).

## Section 5 Utilities Test Program

Every MCE comes with a utilities test program disk that includes a **Windows** version. This program is to verify and demonstrate the functionality of the MCE. In some cases, it can be used as a card reading and writing program.

### System Requirement

1. 80286 PC/AT compatibles or later model with color display.
2. Either the following operating systems: Windows 95, Windows 98, Windows 2000, or NT4.0.
3. 256K available conventional memory.
4. A free serial port (Com 1 or Com 2) with DB9 male connector.

### Test Program Installation

User shall follow the steps below in order to install test program.

- A. Connect MCE to RS232 port, and power on it.
- B. Execute test program from the subdirectory of 'Demo AP' (e.g. 206DDX21.exe)

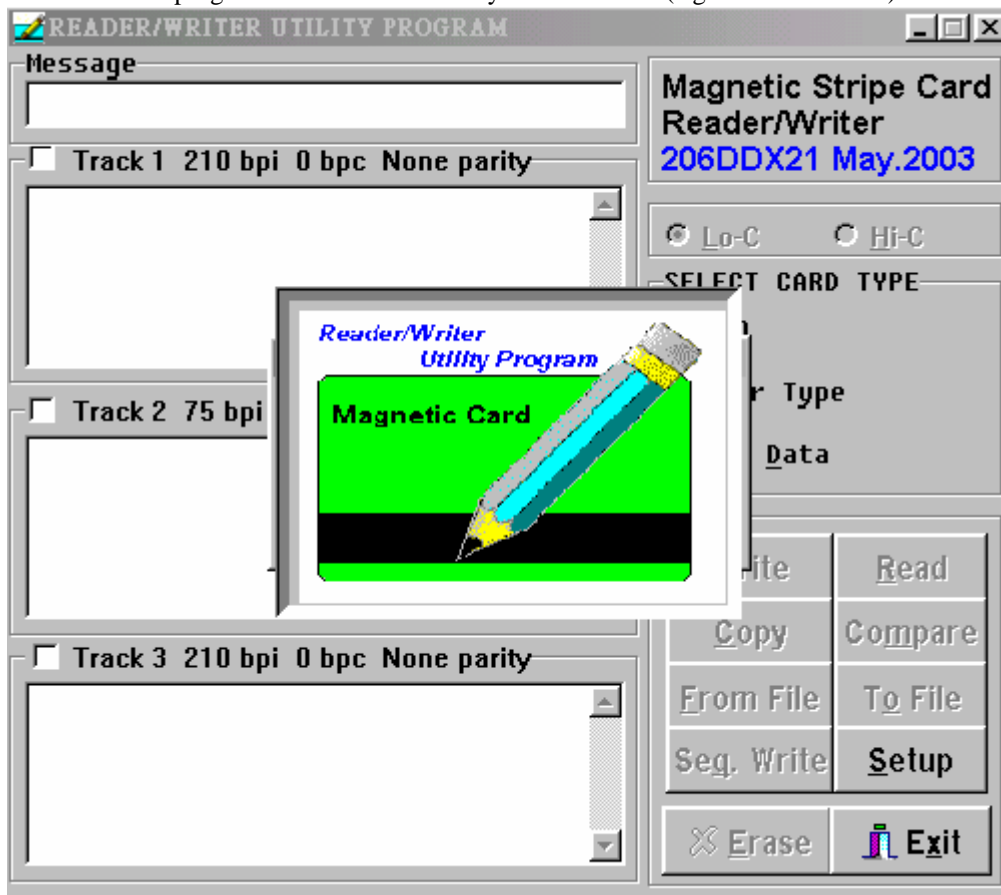

- C. The test program will auto-detect communication port. If there is any errors occurred, it'll appear in the information dialog box after opening the program. User can close the AP by pressing OK button.



- D. If “Not Find Reader/Writer!” appears in the information dialog box after opening the program, check to see that the DB9 connector is plugged into the correct COM port and the power cord/connector is also attached to DB9 thus lighting the green LED on the MCE.

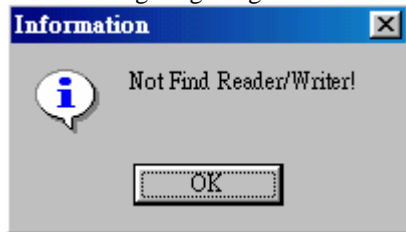

- E. When the test program is first opened, a password dialog box will ask whether you wish a first time password. If yes, enter a password of one or more characters, maximum to 16 characters. And proceed to step G.

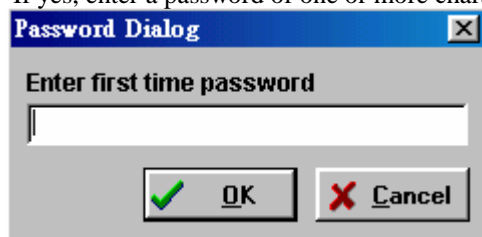

- F. If a password is not required, press ESC and a dialog box will ask you to confirm that a password is not required. Click on Yes and proceed to demo program.

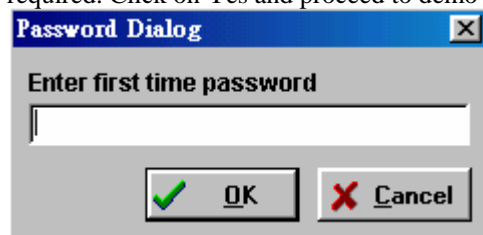

- G. When entering a password for the first time, the system will require you to confirm the password, Click OK, after you reenter your password.

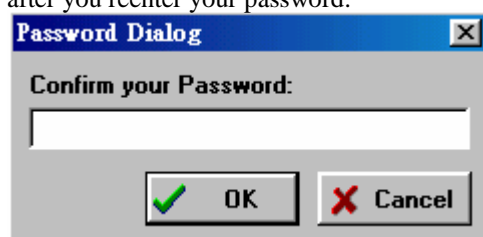

- \* Remember the password you entered, because if it is forgotten, you must re-install the Test Program.
- \* Remember, however; should you desire password protection in the future, you must re-install the program.

H. When the test program is opened, you'll see the main window of the READER/WRITER UTILITY PROGRAM.

From this main window you can activate all functions by clicking the appropriate buttons and following the on screen instructions.

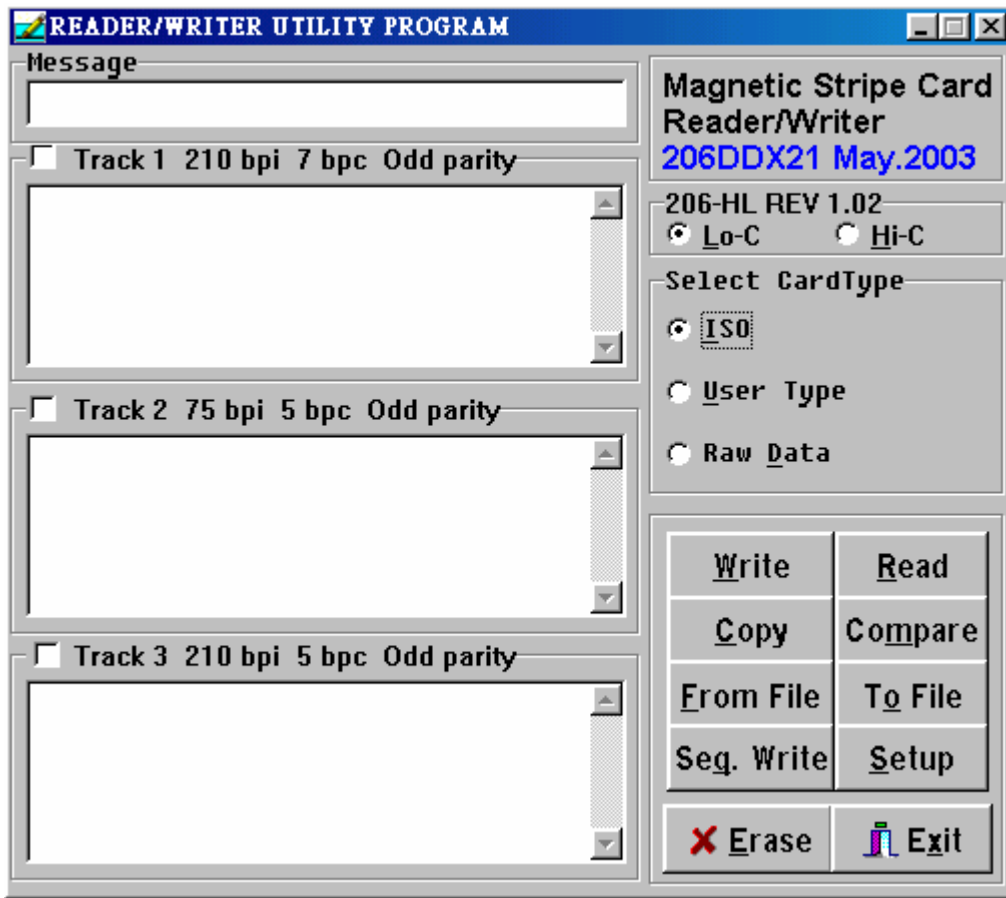

I. The test program will auto detect if a MCE is connected.

By clicking Setup from main window, you can change COM ports, Leading Zeros for all 3 tracks and BPI of track 2.

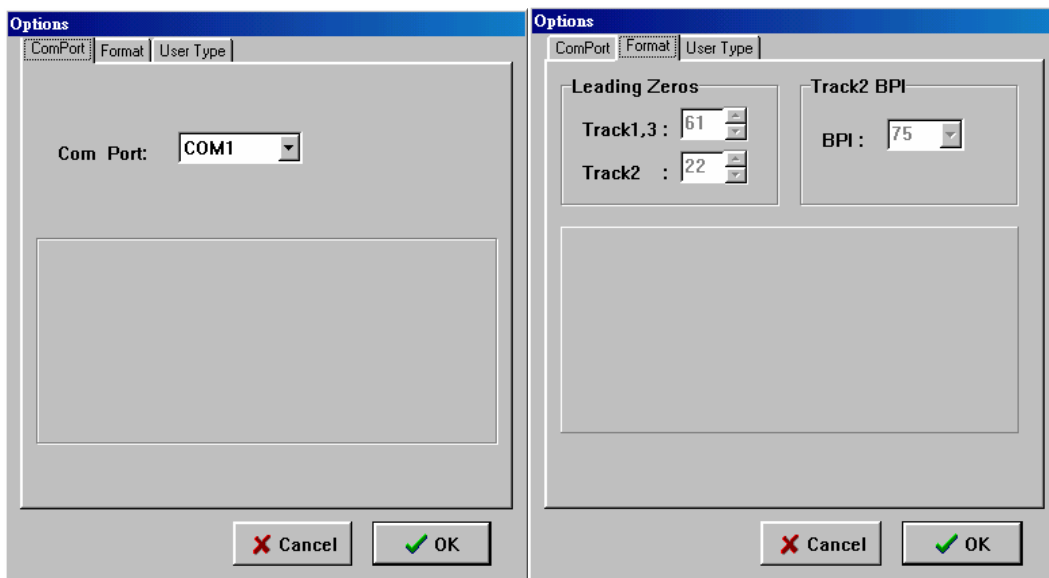

J. By choosing User Type from the main window, you can then define your user parameters by clicking Setup & selecting User Type.

The image shows a software dialog box titled "Options" with a blue header bar. Below the header are three tabs: "ComPort", "Format", and "User Type", with "User Type" being the active tab. The dialog is divided into three sections, each for a different track:

- Track 1:** BPC is set to 7, Parity is set to Odd, SS is set to %, and ES is set to ?.
- Track 2:** BPC is set to 5, Parity is set to Odd, SS is set to ;, and ES is set to ?.
- Track 3:** BPC is set to 5, Parity is set to Odd, SS is set to ;, and ES is set to ?.

At the bottom of the dialog, there are two buttons: "Cancel" with a red 'X' icon and "OK" with a green checkmark icon.

## Section 6 Command and Response

This section gives detailed description of commands to the MCE and the corresponding responses from MCE.

Notional Conventions:

<ESC>	Control character named
[[[ [sname]	Special string named sname, meaning can be found in section 7. ie.[Data Block] [Status Byte] [Select Byte] etc.
X	Standard ANSI character

Command Description:

1. Command: **RESET**

Command code: <ESC> a

Hex code: 1B 61

Response: none

Description: This command reset the MCE to initial state.

2. Command: **READ** (ISO format only)

Command code: <ESC> r

Hex code: 1B 72

Response: [Data Block] <ESC> [Status Byte]

Description: This command request MCE to read a card swiped and respond with the data read.

3. Command: **WRITE** (ISO format only)

Command code: <ESC> w [Data Block]

Hex code: 1B 77 [Data Block]

Response: <ESC> [Status Byte]

Description: This command request MCE to write the Data Block into the card swiped.

4. Command: **Communication test**

Command code: <ESC> e

Hex code: 1B 65

Response: <ESC> y [1B] [79]

Description: This command is used to verify that the communication link between computer and MCE is up and good.

5. Command: **All LED off**

Command code: <ESC> <81>

Hex code: 1B 81

Response: none

Description: This command is used to turn off all the LEDs.

**6. Command: All LED on**

Command code: &lt;ESC&gt; &lt;82&gt;

Hex code: 1B 82

Response: none

Description: This command is used to turn on all the LEDs.

**7. Command: GREEN LED on**

Command code: &lt;ESC&gt; &lt;83&gt;

Hex code: 1B 83

Response: none

Description: This command is used to turn on the Green LED.

**8. Command: YELLOW LED on**

Command code: &lt;ESC&gt; &lt;84&gt;

Hex code: 1B 84

Response: none

Description: This command is used to turn on the Yellow LED.

**9. Command: RED LED on**

Command code: &lt;ESC&gt; &lt;85&gt;

Hex code: 1B 85

Response: none

Description: This command is used to turn on the Red LED.

**10. Command: Sensor test**

Command code: &lt;ESC&gt; &lt;86&gt;

Hex code: 1B 86

Response: &lt;ESC&gt; 0 (1B 30) if test ok

Description: This command is used to verify that the card sensing circuit of MCE is working properly.

MCE will not response until a card is sensed or receive a RESET command.

**11. Command: Ram test**

Command code: &lt;ESC&gt; &lt;87&gt;

Hex code: 1B 87

Response: &lt;ESC&gt; 0 (1B 30) ram test ok; &lt;ESC&gt; A (1B 41) ram test fail

Description: This command is used to request MCE to perform a test on its on board RAM.

12. Command: **Set leading zero**

Command code: <ESC> z [leading zero of track 1 & 3] [leading zero of track 2]

Hex code: 1B 7A [00~ff] [00~ff]

Response: <ESC> 0 (1B 30) set ok

<ESC> A (1B 41) set fail

Description: This command is used to set how many leading zeros will be written before the card data starts, and the space should calculated as [leading zero] X25.4 / BPI (75or210) =mm

Default setting of leading zero: [3D] [16]

TK1 & TK3: [3D] means leading zero=61

TK2: [16] means leading zero=22

13. Command: **Check leading zero**

Command code: <ESC> 1

Hex code: 1B 6C

Response: 1B [00~ff] [00~ff]

Description: This command is used to ask MCE the present setting number of leading zeros.

14. Command: **Erase card**

Command code: <ESC> c [Select Byte]

Hex code: 1B 63 [Select Byte]

Response: <ESC> 0 [1B] [30] command Select Byte ok

<ESC> A [1B] [41] command Select Byte fail

Description: This command is used to erase the card data when card swipe.

\*[Select Byte] format:

00000000: Track 1 only

00000010: Track 2 only

00000100: Track 3 only

00000011: Track 1 & 2

00000101: Track 1 & 3

00000110: Track 2 & 3

00000111: Track 1, 2 & 3

15. Command: **Select BPI** (only for TK2)

Command code: <ESC> b [Density]

Hex code: 1B 62 [D2 or 4B]

Response: <ESC> 0 [1B] [30] select ok

<ESC> A [1B] [41] select fail

Description: This command is used to select the density of TK2.

[D2]: TK2 BPI=210 [4B]: TK2 BPI=75

**16. Command: Read raw data**

Command code: &lt;ESC&gt; m

Hex code: 1B 6D

Response: [Raw Data Block] &lt;ESC&gt; [Status Byte]

Description: This command requests MCE to read a card swipe but send without ASCII decode.

Refer to [Raw Data Block] &amp; [Raw Data] format.

**17. Command: Write raw data**

Command code: &lt;ESC&gt; n [Raw Data Block]

Hex code: 1B 6E [Raw Data Block]

Response: &lt;ESC&gt; [Status Byte]

Description: This command requests MCE to write raw Data Block into the card swiped.

Refer to [Raw Data Block] &amp; [Raw Data] format.

**18. Command: Get device model**

Command code: &lt;ESC&gt; t

Hex code: 1B 74

Response: &lt;ESC&gt; [Model] S

Description: This command is used to get the model of MCE. There are four models:

Model 1, 2, 3, &amp; 5

Models	Description
MCE-1 Track	2
MCE-2	Track 2 & 3
MCE-3	Track 1,2 & 3
MCE-5	Track 1 & 2

**19. Command: Get firmware version**

Command code: &lt;ESC&gt; v

Hex code: &lt;ESC&gt; 76

Response: &lt;ESC&gt; [version]

Description: This command can get the firmware version of MCE.

\* [version] is a 5 bytes version number, format is " REV?X.XX "

MCE? = 0

MCEHC? = H

MCEHL? = U

**20. Command: Set BPC**

Command code: <ESC> o [tk1bit][tk2bit][tk3bit]

Hex code: <ESC> 6F [05-08][05-08][05-08]

Response: <ESC> 30 [tk1bit][tk2bit][tk3bit]

Description: This command is used to set the bit per character of every track.

**21. Command: Set Hi-Co**

Command code: <ESC> x

Hex code: 1B 78

Response: <ESC> 0

Description: This command is used to set MCEHL status to write Hi-Co card.

**22. Command: Set Low-Co**

Command code: <ESC> y

Hex code: 1B 79

Response: <ESC> 0

Description: This command is used to set MCEHL status to write Low-Co card.

**23. Command: Get Hi-Co or Low-Co status**

Command code: <ESC> d

Hex code: 1B 64

Response: <ESC> H -----to write Hi-Co

          : <ESC> L ----- to write Low-Co

Description: This command is to get MCEHL write status.

## Section 7 Data Format

\* [Data Block] format:

	Start Field	R/W Data Field	Ending Field
Command code	<ESC> s	[Card data]	? <FS> <ESC> [Status]
Hex code	1B 73	[Card data]	3F 1C 1B [Status]

\* [Card data] format:

Card	Data
Char Code	<ESC> 1[string1] <ESC> 2 [string2] <ESC> 3 [string3]
Hex Code	1B 01 [string1] 1B 02 [string2] 1B 03 [string3]

\* [Status Byte] format:

Status description		HEX	ASCII
Ok	If read, write or command ok	30h	0
Error	Write or read error	31h	1
	Command format error	32h	2
	Invalid command	34h	4
	Invalid card swipe when in write mode	39h	9

\* Note:

1. When [Status Byte] equal 39h means card moving error.
2. None available and none data tracks will not be transmitted when swipe of card.

For example, when read card with data encoded on track 2 only for MCE-5, it will transmit data like **1B 73 1B 01 1B 02 [string] 3F 1C**, for no data on track 1 so it shown 1B 01 only.

\* [Raw Data Block] format:

	Start Field	R/W Data Field	Ending Field
Command code	<ESC> s	[Raw data]	? <FS> <ESC> [Status]
Hex code	1B 73	[Raw data]	3F 1C 1B [Status]

\* [Raw Data] format:

Raw	Data
Char Code	<ESC>1[L1][string1]<ESC>2[L2][string2]<ESC>3[L3][string3]
Hex Code	1B 01[L1][string1]1B 02[L2][string2]1B 03[L3][string3]

Note:

1. [L1], [L2], [L3] is the length of [string1],[string2],and [string3]
2. None available and none data tracks will not output when swipe of card.

For example, when read card (encoded data on track 2 only) on MCE-5, it will transmit data like **1B 73 1B 01 00 1B 02 [L2] [string] 3F 1C**.



## Section 8 Communication Sequence

The examples below assumes data on track1, 2 & 3 to be 01, 23, 45 respectively.

### MCE INITIALIZATION

HOST	Direction	MCE
Command code: <ESC>a HEX code: [1B][61]	(Reset)	
Command code: <ESC>e HEX code: [1B][65]	(Serial port test)	
		Command test ACK: <ESC>y HEX code: [1B][79]
Command code: <ESC>a HEX code: [1B][61]	(Reset)	

### Write Data to MCE

HOST	Direction	MCE
Command code: <ESC>w<ESC>s<ESC>[01]01 <ESC>[02]23<ESC>[03]45?<FS> HEX code: [1B][77][1B][73][1B][01][30][31][1B] [02][32][33][1B][03][34][35][3F][1C]	(write command)	
	(status ACK)	(Wait until swipe card) Command ACK: <ESC> <status> HEX code: [1B][status] Status =[30] no error Status =[31]~[3F] if error

## Read Data to MCE

HOST	Direction	MCE
Command code: <ESC>r HEX code: [1B][72]	(read command)	
	(status ACK)	(Wait until swipe card) Command ACK: <ESC>s<ESC>[01]%01?<ESC>[02];23?<ESC>[03];45??< FS><ESC><status> HEX code: [1B][73][1B][01][25][30][31][3F][1B][02][3B][32][33][3F] [1B][03][3B][34][35][3F][3F][1C][1B][status] Status=[30]                   ok Status=[31]~[3F]           if error

\* [XX] = HEX Code XX

# Section 9 Addendum

## Write Data to Magnetic Card

The WRITE command:

Command WRITE	
Command code	<ESC> w [Data Block]
Hex code	1B 77 [Data Block]
Response	<ESC> [Status Byte]
Description	This command request MCE to write the Data Block into the card swiped.

[Data Block] format:

	Start Field	R/W Data Field	Ending Field
Command code	<ESC>s	[card data] ?<FS>	
HEX code	1B 73	[card data] 3F	1C

[card data] format:

card	data
Char. code	<ESC>[01] [string] <ESC> [02] [string] <ESC> [03] [string3]
HEX code	1B 01 [string1] 1B 02 [string2] 1B 03 [string3]

As an example the following information will be written to the card:

Track1: %ABC123?

Track2: ;12345?

Track3: ;12345?

HOST	DIRECTION	MSR106/MCE
Command code: <esc>w<ESC>s<ESC>[01]ABC123<ESC> [02]12345<ESC>[03]12345?<FS> HEX code: [1B][77][1B][73][1B][01][41][42][43][31][ 32][33][1B][02][31][32][33][34][35][1B][0 3][31][32][33][34][35][3F][1C]	(write command)  ----->	
After send command to MSR106/206	Yellow LED on, then swipe card	write data to the magnetic card
(status	ACK)	(wait until swipe card) Command ACK: <ESC><status> HEX code: [1B][status] Status = [30] no error Status = [31] ~ [3F] if error



: 1 1 0 1 0					
; (*)	0 1 0 1 1				
<	1 1 1 0 0				
=	0 1 1 0 1				
>	0 1 1 1 0				
? (*)	1 1 1 1 1				

\* Note: The “;” is start sentinel and “?” is end sentinel of tk2 & 3 of ISO format.

As an example the following information will be written to the card:

Track1: %ABC123?

Track2: ;12345?

Track3: ;12345?

We use three different data bits to write raw data on the cards. The procedures are listed as below:

**08, 08, 08 BITS**

Set each track as 08.

First of all, set BPC command:

1B, 6F, 08, 08, 08

Present the information to the card encoder, as follows:

Start Field	1B6E1B73
Track1 header	1B01
Length 08	
Track1 data	C5B07814954E3E2A
Track header	1B02
Length 05	
Track2 data	2B8849EAAF
Track3 header	1B03
Length 05	
Track3 data	2B8849EAAF
Ending Field	3F1C

Transfer the track1 data to HEX under 08 bits:

B0	B1	B2	B3	B4	B5	P
% 1 0 1 0 0 0 1						
A 1 0 0 0 0 1 1						
B 0 1 0 0 0 1 1						
C 1 1 0 0 0 1 0						
1 1 0 0 0 1 0 1						
2 0 1 0 0 1 0 1						

3	1	1	0	0	1	0	0					
?	1	1	1	1	1	0	0					
LRC	0	1	0	1	0	1	0					

Calculate Odd Parity (P column)

If there is an Even Number of 1's in the row of data for each character, put a 1 in the P column. Other wise, put a 0 in the column.

LRC: If there is an Even Number of 1's in the column of data for each character, put a 0 in the LRC row. Other wise, put a 0 in the row. The last LRC will be considered as the parity rule of this row.

B0	B1	B2	B3	B4	B5	B6	B7				
1	0	1	0	0	0	1	1				
0	0	0	0	1	1	0	1				
0	0	0	1	1	1	1	0				
0	0	1	0	1	0	0	0				
1	0	1	0	1	0	0	1				
0	1	1	1	0	0	1	0				
0	1	1	1	1	1	0	0				
0	1	0	1	0	1	0	0				

B7	B6	B5	B4	B3	B2	B1	B0	HEX			
1	1	0	0	0	1	0	1	C5			
1	0	1	1	0	0	0	0	B0			
0	1	1	1	1	0	0	0	78			
0	0	0	1	0	1	0	0	14			
1	0	0	1	0	1	0	1	95			
0	1	0	0	1	1	1	0	4E			
0	0	1	1	1	1	0	3	E			
0	0	1	0	1	0	1	0	2A			

Transfer track 2 (track 3) data to HEX under 08 bits:

B0	B1	B2	B3	P				
;	1	1	0	1	0			
1	1	0	0	0	0			
2	0	1	0	0	0			
3	1	1	0	0	1			
4	0	0	1	0	0			
5	1	0	1	0	1			
?	1	1	1	1	1			
LRC					1	0	1	0

B0 B1	B2 B3 B4	B5 B6 B7				
1 1 0 1 0 1 0 0						
0 0 0 1 0 0 0 1						
1 0 0 1 0 0 1 0						
0 1 0 1 0 1 1 1						
1 1 1 1 0 1 0 1						

B7 B6 B5 B4 B3 B2 B1 B0	HEX				
0 0 1 0 1 0 1 1 2	B				
1 0 0 0 1 0 0 0 8	8				
0 1 0 0 1 0 0 1 4	9				
1 1 1 0 1 0 1 0 E	A				
1 0 1 0 1 1 1 1 A	F				

**07, 05, 05 BITS**

Set TK1, TK2 & TK3 as 07, 05, 05

1b, 6F, 07, 05, 05

First of all, set BPI command:

Present the information to the card encoder, as follows:

Start Field	1B6E1B73
Track1 header	1B01
Length 09	
Track1 data	456162235152131F2A
Track2 header	1B02
Length 08	
Track2 data	0B01021304151F15
Track3 header	1B03
Length 08	
Track3 data	0B01021304151F15
Ending Field	3F1C

Transfer the track1 data to HEX under 07 bits:

B0 B1	B2 B3 B4	B5 P				
%	1 0 1 0 0 0 1					
A	1 0 0 0 0 1 1					
B	0 1 0 0 0 1 1					
C	1 1 0 0 0 1 0					
1	1 0 0 0 1 0 1					
2	0 1 0 0 1 0 1					

3	1 1 0 0 1 0 0				
?	1 1 1 1 1 0 0				
LRC	0 1 0 1 0 1 0				

Calculate Odd Parity (P column)

If there is an Even Number of 1's in the row of data for each character, put a 1 in the P column. Other wise, put a 0 in the column.

Add P	B5	B4	B3	B2	B1	B0	HEX				
% 0 1 0	0 0 1 0 1	1 4 5									
A 0 1 1	0 0 0 0 1	6 1									
B 0 1 1	0 0 0 1 0	6 2									
C 0 0 1	0 0 0 1 1	2 3									
1 0 1 0	1 0 0 0 1	5 1									
2 0 1 0	1 0 0 1 0	5 2									
3 0 0 0	1 0 0 1 1	1 3									
? 0 0 0	1 1 1 1 1	1 F									
LRC	0 0 1 0	1 0 1 0 2 A									

HEX

B3	B2	B1	B0
0 0 0 0			0
1 0 0 0			1
2 0 0 1			0
3 0 0 1			1
4 0 1 0			0
5 0 1 0			1
6 0 1 1			0
7 0 1 1			1
8 1 0 0			0
9 1 0 0			1
A 1 0 1			0
B 1 0 1			1
C 1 1 0			0
D 1 1 0			1
E 1 1 1			0
F 1 1 1			1

Transfer track 2 (track 3) data to HEX under 05 bits:

B0	B1	B2	B3	P
:	1	1 0 1 0		

1	1	0 0 0 0			
2	0	1 0 0 0			
3	1	1 0 0 1			
4	0	0 1 0 0			
5	1	0 1 0 1			
?	1	1 1 1 1			
LRC	1	0 1 0 1			

	Add 0	Add 0	Add 0	P	B3	B2	B1	B0	HEX
; 000	0 1 0 1	1 0 B							
1 0 0 0	0 0 0 0	1 0 1							
2 0 0 0	0 0 0 1	0 0 2							
3 0 0 0	1 0 0 1	1 1 3							
4 0 0 0	0 0 1 0	0 0 4							
5 0 0 0	1 0 1 0	1 1 5							
? 0 0 0	1 1 1 1	1 1 F							
LRC	0 0 0 1	0 1 0 1	1 5						

**06, 05, 06 BITS**

Set TK1, TK2 & TK3 as 06, 05, 06

First of all, set BPI command:

1b, 6F, 06, 05, 06

Present the information to the card encoder, as follows:

Start Field	1B6E1B73
Track1 header	1B01
Length 09	
Track1 data	052122231112131F2A
Track2 header	1B02
Length 08	
Track2 data	0B01021304151F15
Track3 header	1B03
Length 08	
Track3 data	0101020304051F1F
Ending Field	3F1C

Transfer track1 data to HEX under 06 bits:

B0 B1	B2 B3	B4 B5				
% 1 0 1 0				0	0	
A 1 0 0 0				0	1	

B 0 1 0 0				0	1
C 1 1 0 0				0	1
1 1 0 0 0				1	0
2 0 1 0 0				1	0
3 1 1 0 0				1	0
? 1 1 1 1				1	0
LRC	0 1 0 1			0	1

Add	0	Add	0	B5	B4	B3	B2	B1	B0	HEX
% 0 0 0	0 0 1 0 1	0 5								
A 0 0 1	0 0 0 0 1	2 1								
B 0 0 1	0 0 0 1 0	2 2								
C 0 0 1	0 0 0 1 1	2 3								
1 0 0 0	1 0 0 0 1	1 1								
2 0 0 0	1 0 0 1 0	1 2								
3 0 0 0	1 0 0 1 1	1 3								
? 0 0 0	1 1 1 1 1	1 F								
LRC	0 0 1 0	1 0 1 0 2 A								

Transfer track 2 data to HEX under 05 bits:

B0	B1	B2	B3	P
; 1 1 0 1 0				
1 1 0 0 0 0				
2 0 1 0 0 0				
3 1 1 0 0 1				
4 0 0 1 0 0				
5 1 0 1 0 1				
? 1 1 1 1 1				
LRC	1 0 1 0 1			

	Add 0	Add 0	Add 0	P	B3	B2	B1	B0	HEX
; 0 0 0 0					1 0 1 1	0 B			
1 0 0 0 0					0 0 0 1	0 1			
2 0 0 0 0					0 0 1 0	0 2			
3 0 0 0 1					0 0 1 1	1 3			
4 0 0 0 0					0 1 0 0	0 4			
5 0 0 0 1					0 1 0 1	1 5			
? 0 0 0 1					1 1 1 1	1 F			
LRC	0 0 0 1				0 1 0 1	1 5			

Transfer track 3 data to HEX under 06 bits:

B0 B1	B2 B3	B4 B5				
! 1 0 0 0 0 0						
1 1 0 0 0 0 0						
2 0 1 0 0 0 0						
3 1 1 0 0 0 0						
4 0 0 1 0 0 0						
5 1 0 1 0 0 0						
? 1 1 1 1 1 0						
LRC	1 1 1 1 1 0					

Add	0	Add 0	B5 B4	B3 B2	B1 B0	HEX		
! 0 0 0 0 0 0 1 0 1								
1 0 0 0 0 0 0 1 0 1								
2 0 0 0 0 0 0 1 0 2								
3 0 0 0 0 0 0 1 1 0 3								
4 0 0 0 0 0 1 0 0 0 4								
5 0 0 0 0 0 1 0 1 0 5								
? 0 0 0 1 1 1 1 1 1 F								
LRC	0 0 0 1 1 1 1 1 1 F							